

Turntable Manual for MKV Aurora-Swift-Calyпсо- Resolution

IMPORTANT NOTES

The turntable has a ball-bearing which must be dropped into the bearing house before inserting the oil and spindle.

Set speed after 48 hours of continuous running as described in this manual.

Never stretch the belt except to place it over the pulley. If you test stretch the belt you can damage it resulting in future breakage

It cannot be overstated that it is **VERY** important to read these instructions or the speed control may not function accurately.

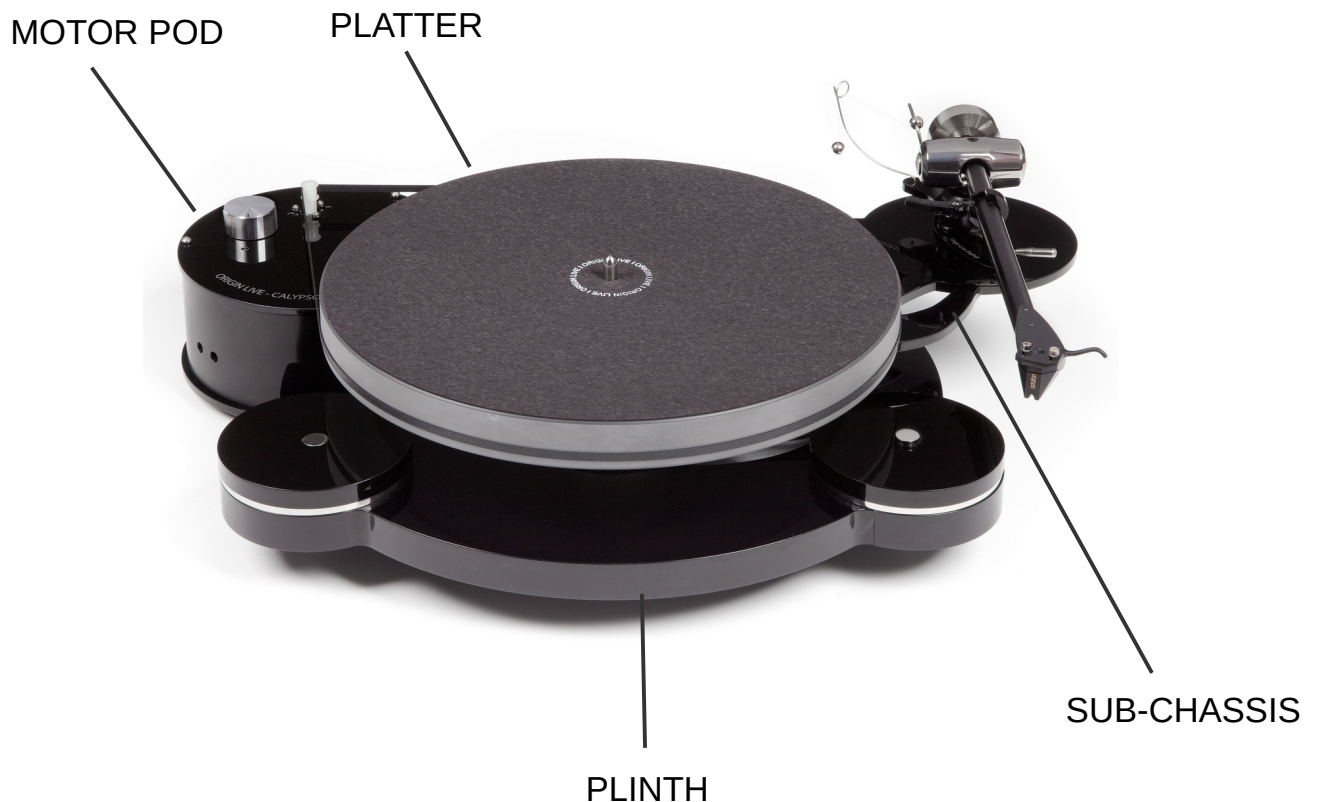

Arm shown is not included

Introduction

Congratulations and thank you for choosing an Origin Live turntable. This should give many years of enjoyment, reliability and low maintenance.

It's critical that these instructions are read fully to achieve best performance. Underlined text is especially important.

The instructions are written for owners with no previous experience, however there are aspects of the deck that run contrary to expectations, so experts should not alter anything without absorbing these instructions first.

Diagrams cover 3 different turntables so are for guidance not exact representation.

Origin Live turntables are simple to set up. The instructions appear lengthy because they give proper explanation of factors that are different to conventional set ups. If you have a problem not covered in the instructions - you should speak to your dealer or refer to technical support on the Origin Live web site www.originlive.com - See top navigation bar "support".

There is a wealth of 3rd party information online. YouTube videos are particularly helpful on how to set up cartridges and tonearms should you need more help – Just Google what you need to know.

Keep the turntable packing box for secure future transport.

Safety Warnings

Voltages inside the Motor Pod are dangerous so it must not be opened.

Ensure Mains lead to the Motor Pod cannot be pierced by spikes or similar abuse. Also ensure the lead cannot cause anyone to trip.

Furthermore keep mains lead away from areas where liquids could spill on it.

Parts list

- ◆ Plinth & Sub-chassis - including 1 cable clip with nut & bolt.
- ◆ Bag of parts
 - Cork washer for arm
 - Small screw driver
 - Oil bottle + ball bearing
 - 2.5mm allen key for arm clip
 - 3mm Allen key
 - 4mm Allen key
 - 8mm A/F spanner – (12 inch arms only)
 - Screwdriver
- ◆ Platter
- ◆ Upgrade platter mat (if you have multi-layer platter this is attached to it)
- ◆ 1 Belt + Spindle for platter + ball + Strobe card
- ◆ Motor pod
- ◆ Owner manual, assembly sheet, Packing instructions

Set up & operation

Sub-chassis for 12 inch tonearms need to be assembled to Plinth

Fit the 12 inch sub-chassis version to the deck as per instruction sheet at the beginning of this booklet.

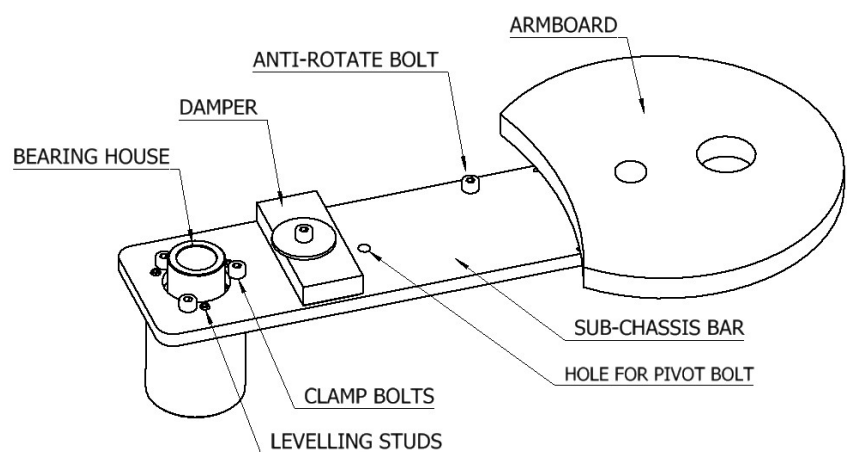

Note the above diagram is for guidance only – it's not an exact representation.

Fit the Spindle

Drop the ball into the bearing house

Drop the metal ball into the bearing house before inserting the oil and spindle. It should self-centre at the bottom but check this is the case by looking into the bearing house.

Oil the bearing

Run the oil supplied into the top of the bearing house until the top of the ball is just covered. The spindle will appear a loose fit in the bearing house until the oil is added. Do not use anything other than Origin Live oil for performance reasons.

Insert the spindle

Inserting the spindle into the bearing house needs attention as careless handling can damage the bearing surfaces. Wipe the spindle surface first to ensure that it's absolutely clean and very gently insert it into the bearing house. If the oil does not overflow when the spindle touches the bottom then try 2 more drops repeatedly till you achieve overflow. Overflow can only be seen by looking at the top of the bearing house with the spindle inserted. You should notice an oil ridge around the spindle – see diagram below.

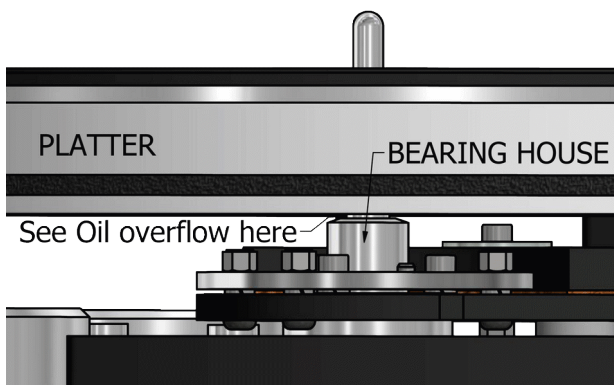

Wipe away excessive overflow at the top of the bearing house but be careful to leave oil clinging to the spindle as you need the top of the bearing to be lubricated by oil overflow and things like tissue paper can suck this area dry by capillary action. You should spin the spindle slowly after it has settled into the bearing to ensure even distribution of oil.

Note that when you oil the bearing, you can get a false impression of overflow if the spindle has oil on it - the oil simply scrapes off as the bearing slides in and ends up on the top of the bearing house. You can “feel” overflow when you insert the spindle and it meets resistance at the bottom. This is not a “thud” of the spindle hitting the bottom but rather a build up of pressure as the bearing lands on a bed of oil. By further pressing, you can then see the oil being squeezed out at the top.

Notes on the Bearing:

The bearing has significant play “rock” which runs counter to expectations. However, this feature achieves very low friction levels. The spindle effectively rotates on a thick film of oil without contacting the bearing sides.

This means there is almost imperceptible platter movement in rotation. Small low frequency deviations of this nature are insignificant to performance and far outweighed by the advantages of low friction and reduced vibration.

All platters are rigorously checked for level spinning up to 45rpm - if you notice significant platter flutter once the belt is fitted, then remove the platter and clean taper surfaces. Refit it till it sits true.

Do not spin the platter faster than 45rpm as the bearing relies on a high precision oil film designed for optimal sound quality within a specific speed range. At higher than normal running speeds there will be slight platter flutter.

Fit the Platter

Fit the platter gently over to the spindle but ensure the tapered mating surfaces are absolutely clean before assembly by wiping with tissue paper.

Once the platter is located on the spindle press it down firmly at the centre using your fingers to provide equal force on either side of the spindle. This ensures accurate seating of the platter on the tapered spindle.

Finally add the platter mat ensuring the printed logo is uppermost for sound quality reasons. **Note** – the mat is already fitted if you have a Multi-Layer platter (see below).

Platter Notes

Holding the Multi-layer platter

The top thin layers of the multi-layer platter are fragile so do not hold the weight of the platter using the top layers – also avoid placing the platter upside down on surfaces as this can damage the top surface.

Concentricity of upper Layers

The upper layers of the platter work best as a loose fit. This means that there can be very slight movement of the layers when pushed.

This is not a design flaw but you may notice that the layers are not always perfectly concentric with the platter. Performance is not affected however as the centre spindle is absolutely concentric with the platter which means your record will be held concentric (unless it's hole is off centre).

Set the Height of the Plinth

To set the plinth height correctly, place the motor pod just beside the platter as shown below.

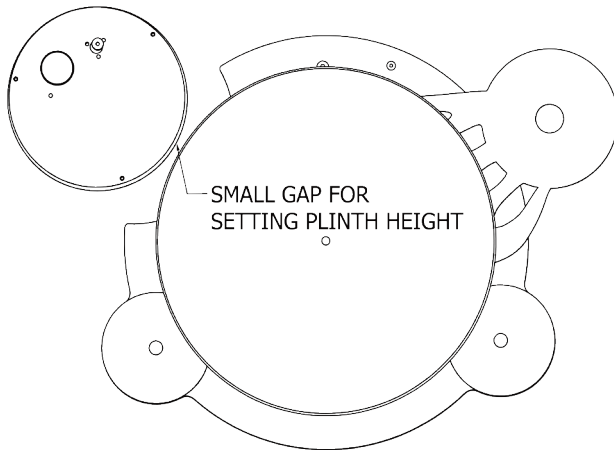

Set plinth height using the adjustable feet, to give the platter 4 to 7mm clearance between the top of the motor pod screws and the underside of the platter as shown below.

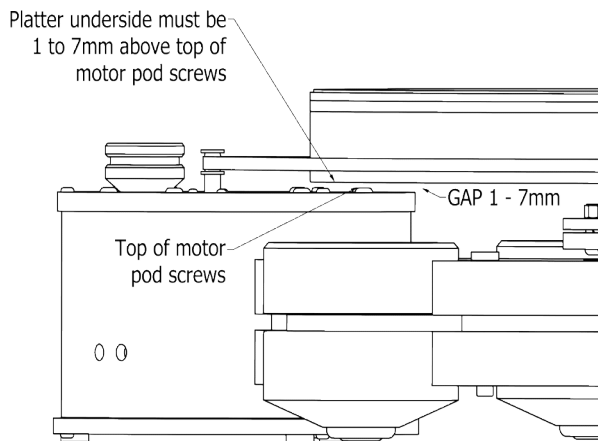

Adjust deck feet

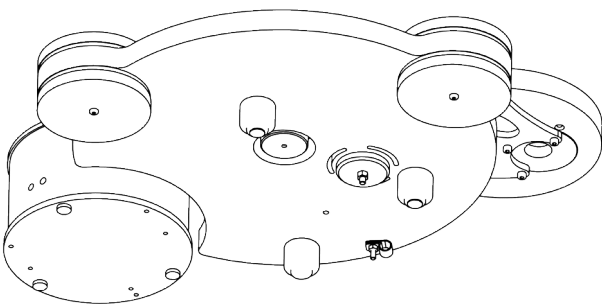

FOOT

Set the plinth height by rotating the 3 adjustable feet. It helps to lift the deck slightly for access to each foot in turn.

The top of each foot should not touch the underside of the plinth as performance is best when the foot contacts the thread alone.

Level the deck using platter as reference

For accurate levelling place a bubble gauge on the platter. Now adjust the feet till the armboard is level.

Position motor pod & fit belt

Power up

Plug the Motor Pod directly into a mains plug. We suggest omitting mains conditioners, filters or anything with surge protection as these can be highly detrimental for performance. The aforementioned items inflict no damage so you can experiment with their inclusion if you wish.

Ensure items such as power amps or power supplies with strong electromagnetic fields are kept away from the motor pod (i.e not directly underneath or alongside).

Motor Pod position

Move the pod into position as shown below. The pod and pod cable should not touch the plinth so rotate the pod if necessary. Check the pulley to platter distance is initially 217mm or slightly more.

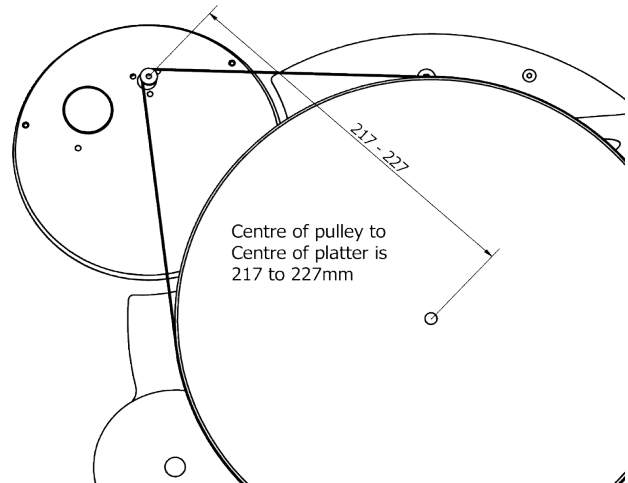

Fit the belt over the platter first and then pull it over the motor pulley taking care not to twist it.

To set belt tension, simply move the pod.

As a rough guide, centre of platter spindle to centre of motor pulley should be between 217 - 227mm. Note - Low belt tension can result in slight platter flutter but for a new belt start at 217mm.

The belt initially stretches slightly during the first hours of use so leave final tension adjustment till 48 hours have passed.

***The only time you should ever stretch the belt is to place it over the pulley. If you test stretch the belt you can damage it resulting in future breakage. Never pull the belt on either side of the glued joint to see how strong it is.

Final positioning of motor pod

To set correct belt tension finally, lift the belt off the pulley and let it lose its tension almost completely whilst still holding it gently - With no tension

whatsoever in the belt it should be approx 7mm off the nearside of the motor pulley (flange edge) as per diagram below. Move the pod till the pulley is this distance from the belt, then stretch the belt to fit over the pulley.

BELT UNSTRETCHED SHOULD BE 6 to 9mm from Pulley flange

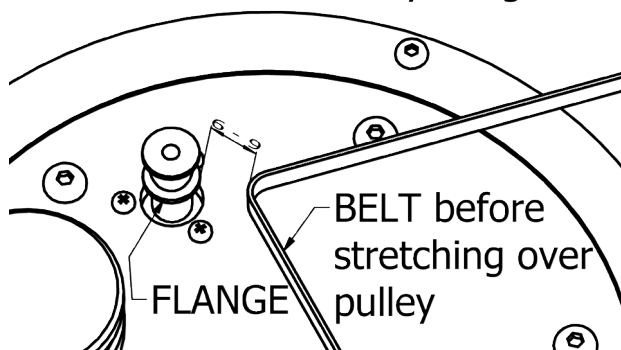

Check belt rides correctly

Rotate the platter by hand for a couple of turns and check that the belt still sits between the 2 flanges of the pulley. If this is not the case and it has ridden up onto a flange push the belt back onto the crown (Curved portion between the flanges) and turn the platter. Check the belt remains on the crown.

BELT RUNNING POSITION

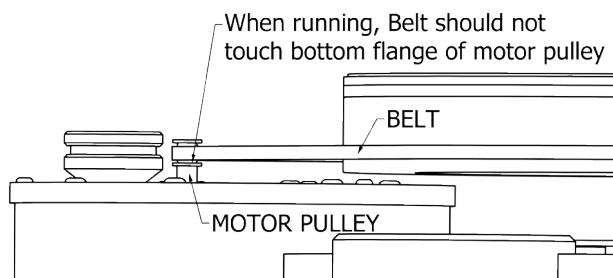

People sometimes comment that the plastic pulley looks cheap - However it's made from a special plastic which sounds better than metal and is significantly more expensive to machine.

Note that belt grip varies according to the way it's fitted. This means the deck will sound slightly different if you refit the belt inside out or upside down from previously. Therefore when removing and refitting the belt take care to replace it with the same side in contact with the running surfaces.

Set Motor Speed



Operating the drive speed control

The drive speed is set at factory but will change during the first 48 hours of running as the circuit and motor bearings settle down. For this reason you should set the speed yourself using one of the methods described in Appendix 1.

Also note that the speed will vary with belt tension so avoid moving the pod once you have positioned it and set the speed,

You will notice 2 holes next to the blue LED. Inside each hole is a slotted screw which when turned clockwise increases the speed (anti-clockwise reduces the speed).

You will need a method to read the speed correctly and this will be covered in the next section as there are various options.

Speed setting and adjustment

The motor is "off" when the speed control knob on the pod is turned fully anti-clockwise and the indent on the knob aligns to the blue LED.

Turn the knob one click clockwise to turn the motor on at 33.3 rpm - The second click clockwise is 45rpm.

Turn the speed control Knob 1 click clockwise for 33rpm speed and adjust the speed of the 33rpm speed screw till speed is correct. Refer to above photo to adjust the correct screw.

Then turn the knob a further click anti-clock-wise and adjust the 45rpm screw till speed is correct.

Important notes regarding speed

Bear in mind that the speed will vary slightly if you move the motor pod position.

It can also vary over the 1st week or so of use as the

circuit runs in and bearings bed down. So we recommend that after a week of so you re-adjust the speed.

How to measure your platter speed

Speed is measured in revolutions per minute. There are 3 methods we recommend you measure the speed.

- a) Mobile phone app
- b) Strobe
- c) Counting revolutions per minute

Please see Appendix 1 at end of this manual for details.

Tension of Motor mounting screws

It should not be necessary but you can fine tune the motor mount to give minimum noise by adjusting the tightness of the 3 screws next to the motor pulley for minimal tension - "just nipped" on the small rubber O ring. Always check that the motor pulley is approximately vertical and that the belt runs clear above the bottom flange as per earlier diagram.

If you notice the belt vibrating significantly then try moving the pod AND rotating it slightly. This adjusts the tension and pulley angle enough to reduce vibration. It can sometimes help to reduce the tension on the motor screw nearest the platter.

Motor "running in" should be carried out with platter turning (no faster than 45rpm).

Notes on Belt & Motor running

Motor Tilt

Check that the belt rides clear of the flanges – nearly touching is OK but if the belt sinks down to touch the flange you need to either increase belt tension slightly or adjust the tilt of the motor by turning the small cross-head motor mounting screw positioned nearest the platter.

Motor Noise

DC motors are often slightly noisy initially and never completely silent in comparison to a/c motors. This may be due in part to the high conductivity precious metal brushes. These produce much lower levels of vibration and hence better performance.

Like most turntable manufacturers we recommend you leave the turntable running between changing records as this reduces belt wear due to constant stopping and starting.

Fit the tonearm

Mounting Origin Live arms

All newer Origin Live arms have built in VTA adjustment and can be fitted directly to the arm board as illustrated below.

If you have an older Origin Live or Rega tone-arm which

has a threaded base but no vta adjustment, you can fit a threaded VTA adjuster. The adjuster must be threaded onto the base of the arm first and oriented such that the flange is uppermost.

Insert your arm through the hole in the arm board.

Next fit the cork washer followed by the large clamping nut as shown in the diagram on this page.

Lastly fit the tone-arm cables through the cable clip on the underside of the deck. This improves performance slightly and safeguards the cables from stressing their joint at the arm base in the event of being "tugged". The cables should not be tight but form a gentle loop.

If clamping the cable is undesirable you can omit this step. We will cover setting the arm to exactly the correct height later as you need to do a number of other things first.

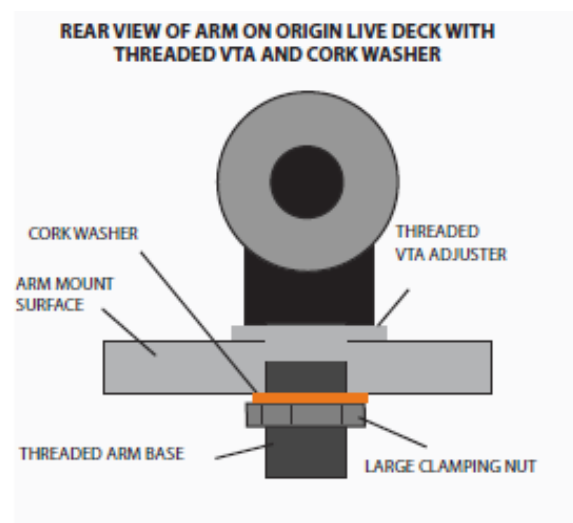

Final setup of tonearm

You should refer to your tone-arm instructions for detailed set up of the arm and cartridge alignment.

Fit the arm cable clip

Pass the arm cable through the cable clip supplied and fasten in position with the M5 bolt located in the threaded hole near the rear foot. Leave a slight droop on the cable so that it isn't "tight". The bolt is helpful to minimize cable vibration.

Note – Silver Hybrid cable is relatively thick but both left and right channels will fit through one of the cable clips supplied.

Maintaining your deck

Cleaning

To avoid belt vibration or wow & Flutter, it aids performance to clean all running surfaces every 3 months with mentholated or surgical spirit. Wiping (not dipping) with Acetone (Nail Varnish remover) is an alternative, as is iso-propanol.

Belts can also be cleaned with soap & water then rinsed thoroughly. Rubber care products can leave behind a slippery residue.

To clean the deck, use a damp soft lint free cloth and wipe gently – if you have grease marks etc then you can use a general-purpose anti-smear, car window cleaner such as Auto-glym “Fast glass”, but only if necessary. Wax furniture polish is to be avoided. Do not spray directly on the turntable as it may clog up the cartridge internals etc but rather spray onto a soft polishing cloth and then use it on the turntable. Do not use tissue paper or kitchen cleaning paper towels as paper is abrasive and can put faint scratches in the polished surface.

Scratch removal

If minor abrasions occur on the surface, you can remove them using a proper plastic scratch remover polish such as “Xerapol” by E.V.I of Germany or “Plastic Clean & Shine by Novus inc of USA. Avoid Car and other polishes as they leave light scratching or bloom.

Every 2 Years or so

The deck is not prone to going out of tune:

Check that the sub-chassis curved damper is tensioned lightly onto the plate every 2 years or so as the damper can compress a little over time.

Check belt tension is correct using the method described for final pod positioning. All belts stretch over the years so the motor pod may need to be moved out further than the initially specified 227mm maximum.

Depending on your use of the deck, the belt should ideally be replaced every 2 to 4 years.

Every 3 years

Only use Origin Live oil. Oil should be replaced every 3 to 4 years so you will need to clean out the old oil with a lint free paper towel or similar wrapped around a thin rod. When you do this, be sure to also wipe oil off the spindle as this may contain microscopic contamination that's not visible.

If you ever withdraw the main spindle you should put a few drops of oil into the bearing house to compensate for any possible loss occurring in the withdrawal.

Never tamper with the bolt in the bottom of the bearing or oil leaks will occur and you will probably not succeed in re-tightening it.

Alternative Mats?

Many of the mats on the market have been tried on our platters and do not work better than our own award winning mat (included with this turntable) so we recommend saving yourself the expense of trying them.

Troubleshooting

Refer to the Origin Live website > Support > Technical Support > Turntables > Troubleshooting if you have any problems.

APPENDIX 1

Operating a strobe

You can check the speed of your deck by placing the strobe disc supplied with your deck, on the record to be played. The strobe rings are labelled on the centre of the disc for speed and mains frequency.

Use correct lighting

The strobe effect shows best in fluorescent light, although an ordinary bulb held about 2 feet from the strobe disc will also work fine. The bulb flickers at 50 Hz in the EEC and 60 Hz in the USA.

You can purchase bayonet fitting fluorescent or halogen bulbs to fit normal lamps. Try to shut out daylight when carrying out speed reading. Also be aware that energy saving lighting with switch mode high frequency power supplies or LED energy saving bulbs will not work with the strobe disc.

Reading the strobe

As you play the record. watch the relevant ring on the strobe disc. Read the speed as described in next sub-heading until marks on the ring concerned appear stationary. It sometimes helps to stare the strobe but focus your eyes on infinity.

Alternative stobes

There are other strobes which are much easier to read such as the KAB strobe which can be found on our web site under vinyl measurement accessories.

Phone Apps

There are phone apps that you can download for Android or Apple. You simply then place the phone on the platter and it reads the speed fairly accurately. Best results are achieved with the phone placed close to the centre of the platter and ideally it should be supported over the centre spindle of the platter - a tape reel or record weight is ideal for support.

Mobile phone apps for measuring rotation speed are incredibly convenient and usually cost nothing. However they should be checked for accuracy against a strobe and calibrated if possible. If you know what your phone reads when a player is running at 33.33rpm (checked with a strobe), then you know that using your phone app is accurate.

For example, say you have set the speed of your deck to 33.33rpm using a strobe. When you place your mobile phone on the platter it reads 33.45 – you now know that when your mobile shows the speed as 33.45 then the speed is really 33.33.

For iphones we recommend the “rpm pro” app as you can calibrate it to the correct speed using a strobe.

Counting Platter Revolutions

If you have problems using the strobe card, then count the rpm using the following method. Counting the 33.3

revs per minute is best accomplished by placing a small piece of sticky tape on the perimeter of the platter and then counting 100 revolutions. 33.3 rpm is exactly 100 revolutions completed in 3 minutes. To save time in the early stages it is easiest to count 50 revs in 1 minute 30 seconds (or 25 revs in 45 seconds) and save the 100 count for the final check.

How some measurements systems can be misleading

It's worth mentioning that the Fleikhart measurement system is now well reported on the web to be inaccurate due to off-centre discs a weakly recorded tone. It has currently been withdrawn from production.

REPACKING METHOD - Please read carefully and pack exactly as instructions show.

BOTTOM LAYER OF PROFILED CARDBOARD



Wrap plinth in polythene bag before lowering into box

Place foam insert into cut out here and align foam cut outs with the cut outs in the card underneath.



Place motor Pod on foam in the orientation shown.

Note Motor pod feet must fit into foam cut outs underneath and the silver switch on top must be exactly where shown to avoid fouling the top layer of profiled cardboard yet to be added.

Insert Motor lead into side pocket as shown

INSERT TOP LAYER OF PROFILED CARDBOARD

Ensure this layer fits below the top flaps of the box. Also ensure that fit is snug on top of motor pod and that the motor pod switch has clear space over it.



Wrap platter and mat in polythene bag before placing it **upside down** in foam cut out



Place bag in side pocket

- Bag Contains: Strobe card
- Belt (Rolled up into a spiral to avoid deformation),
- Cork washer for arm,
- Oil bottle (in polythene bag)
- Allen keys 4mm, 3mm & 2.5mm

Place card rectangle over platter to protect it from knife cut when box is sliced open.

Instruction manual

